

# cantilever table

cantilever table was designed with collaborative workspaces and events in mind. The flat-pack base uses flexible honeycomb geometry to fan open and connect to itself via magnetic end panels. The round bases are made from paper or textile, and paired with a tabletop made from PaperStone® or Carrara marble.

The brown and blue paper table bases are made from wood harvested from Forest Stewardship Council® Certified (FSC® C158591) responsible sources and coated with a non-toxic fire retardant. The white and aluminum textile folding table bases are a nonwoven polyethylene that is water- and tear-resistant. Both materials are recyclable.

PaperStone® tops unify the system's materiality by pairing the folding bases with a thin, lightweight, durable surface that has the warm feel of hardwood yet is made from compressed FSC® certified paper and resin. The tabletops are available in two styles—with or without a central hole. The version with a hole comes with a multifunctional glass centrepiece that acts as a pencil holder and spindle for a stack of paper sketching circles. The circular sheets of paper revolve around the pencil holder to share and develop thoughts around the table. When used for a dining table, the sketching circles can be removed, and the glass centrepiece can be used for chopsticks or as a flower vase.

molo also offers the folding base on its own as an opportunity to share the design process, encouraging clients to pair the bases with tabletops made from local materials. To discuss your idea or request a marble tabletop, please contact the studio.

Design by Stephanie Forsythe + Todd MacAllen



This drawing and the content represented is the exclusive property of molo design ltd. and cannot be used without their prior written consent. For site installations verify all dimensions and notify molo of any on-site discrepancies prior to construction. Drawing scale may be affected by printing, scanning, or copying. Do not scale drawings.



molo design, ltd.  
1470 Venables Street  
Vancouver, BC  
Canada V5L 2G7

+ 1 604 685 0340  
molodesign.com

Designed by Stephanie Forsythe and Todd MacAllen,  
manufactured by molo and protected by one or more patents and/or design registrations held by molo, viewable at molodesign.com/ip

METRIC DRAWING SET

## OVERVIEW

cantilever table was designed with collaborative workspaces and events in mind. The flexible honeycomb bases are made from paper or textile, and pack flat for transport or storage. They pair with a tabletop made from marble or PaperStone®. The brown and blue paper bases are FSC® Certified, and PaperStone® tops provide a lightweight, durable surface made from compressed FSC® certified paper and resin.

The tabletops are available in two styles with or without a central hole. The version with a hole comes with a glass centrepiece that acts as a pencil holder and spindle for a stack of paper sketching circles. The circular sheets of paper revolve around the pencil holder, allowing ideas to grow and develop as they pass around the table. When used for a dining table, the sketching circles are removed, and the glass centrepiece can be used for chopsticks or as a flower vase. Multiple bases may be connected and paired with modular tabletops to create any length or shape of table.

## SUSTAINABILITY

The soft collection follows three core sustainable principles: flexible use of space, efficient use of material, and recyclable/responsible materials.

Flexible use of space · Enabling a space to suit diverse use over time, throughout the day or over its lifespan, is an inherently sustainable practice. The soft collection requires no tools or additional supports to create freestanding structures and is easily folded away for storage. Whether for the temporary division of space in a live / work environment or shaping space for the unpredictable growth of a new business, the soft collection empowers people to change and adapt their spaces.

Efficient use of material · By virtue of its honeycomb cell structure, the soft collection makes highly efficient use of its material and can be easily re-compressed for efficient storage or shipping.

Recyclable/responsible materials · cantilever table is designed with the intention of a long, useful life. Nevertheless, the materials can be recycled. After removing the magnets from the end panels, recycle the remaining material. textile softwall is 100% polyethylene, number “2” in the recycling stream, and paper softwall can be recycled with any regular paper recycling program.

## PAPER · MATERIAL

cantilever table base is offered in three paper colour choices — brown, blue and black. brown and blue paper furniture is made from wood harvested from FSC® Certified (FSC® C158591) responsible sources. All paper products have been produced with non-toxic fire retardants, adhesives and inks.

We do not recommend using paper products in extreme humidity environments, where cantilever table base may come into contact with moisture.

## TEXTILE · MATERIAL

Made from non-woven polyethylene, textile is tear- and water-resistant, anti-static to repel dust and has a natural UV protection that prevents yellowing with sunlight or age. The translucent material has a delicate appearance reminiscent of Japanese washi and comes to life when illuminated by sunlight or integrated LED. textile cantilever table base has a “Class A” rating for flame spread and smoke, developed in accordance with ASTM E84-05. All products made with the textile are easy to maintain and can be dusted, vacuumed or wiped clean with a damp cloth. The textile is 100% recyclable.

## PANTONE CODES FOR STANDARD molo COLOURS

Here is a list of the closest Pantone matches for molo colours and materials:

brown paper: Pantone 7565U

blue paper: Pantone 293 U · blue

deep blue paper: Pantone 19-4053TPG

black paper: Pantone 19-0000 TPG/TCX · raven

black textile: Pantone 19-0405 TPG/TCX · beluga

white textile: Pantone 11-4001 TPG/TCX · brilliant white (also matches Corian Glacier White)

aluminum textile: Pantone 877 C · metallic

forest green textile: Pantone 7742 U

## FIRE CERTIFICATIONS

|                                    |  |
|------------------------------------|--|
| M1 · France                        | <ul style="list-style-type: none"> <li>· all paper products</li> <li>· FR textile (standard textile is Class A — see below)</li> </ul> <p>French NF P 92 503-507 (M1) 504 rate of flame spread test. The test material is classified into 5 categories that define the fire resistance of materials: M0: non-combustible, M1: combustible (non-flammable), M2: combustible (flame retardant), M3: combustible (moderately flammable), M4: combustible (highly flammable), NC: not classified.</p>  |
| B1 · Germany                       | <ul style="list-style-type: none"> <li>· all paper products</li> <li>· FR textile (standard textile is Class A — see below)</li> </ul> <p>German DIN 4102-1 defines fire behavior classes for building materials and specifies requirements and test methods for each class. The test material is classified into 5 categories that define the fire resistance of materials: A1 + A2: fireproof materials, B1: not easily flammable, B2: flammable, B3: easily flammable. B1 (Brandschacht) is the main test method in Germany which measures reaction to fire and is considered the highest flammability standard in the country.</p> |
| NFPA 701 · United States           | <ul style="list-style-type: none"> <li>· all paper products</li> <li>· FR textile (standard textile is Class A — see below)</li> </ul> <p>NFPA 701 testing measures the ignition resistance of a fabric after it is exposed to a flame for 12 seconds.</p>   |
| ASTM 84-05 Class A · United States | <ul style="list-style-type: none"> <li>· all textile products — if M1 or B1 is required, please inquire</li> </ul> <p>Class A fire rating represents the highest rating achievable, indicating a flame spread of 0 - 25 and smoke developed between 0 - 450. A designation of Class A, or Class I, is considered superior fire protection.</p>   |

## ACOUSTICS

There are two ways that cantilever table base improves acoustics. First, their pleated forms break up a room's flat, typically parallel surfaces, reducing sound reflection and standing waves. Second, the sound is absorbed by its honeycomb structure, reducing sound transmission through the partitions.

See NRC test results for softwall + softblock and cloud softlight below. benchwall will similarly absorb sound in a space as they all share the same type of honeycomb structure and pleated form.

NRC stands for Noise Reduction Coefficient. It is a rating system that explains how much sound an acoustic product can absorb. Ratings range from 0 to 1. An acoustic product with a 0.95 NRC rating means that 95% of the space's noise is absorbed, while 5% is reflected. molo softwall + softblock modular system has an average absorption range of 0.25 - 0.50.

NRC = 0.25 · 9.25” (23.5 cm) wide softwall + softblock

NRC = 0.30 · 13.3” (34 cm) wide softwall + softblock

NRC = 0.50 · 17.75” (45 cm) wide softwall + softblock

NRC = 0.45 · cloud softlight

\* softwall + softblock NRC tests have been completed in textile and paper materials, resulting in the same NRC values.

Other soft collection products, such as partitions, lighting, and seating, will absorb sound in a space as they all share the same type of honeycomb structure and pleated form.

## FSC® CERTIFIED

molo brown and blue paper furniture is made from wood harvested from FSC® Certified (FSC® C158591) responsible sources and coated with a non-toxic fire retardant.

The Forest Stewardship Council GmbH is an international non-profit, multistakeholder organization established in 1993 that promotes responsible management of the world's forests via timber certification. The FSC certification is considered the “gold standard” designation for wood harvested from forests that are responsibly managed, socially beneficial, environmentally conscious, and economically viable.

## LIGHTFASTNESS · OVERVIEW

| Lightfastness is a property of a colourant such as dye or pigment that describes its resistance to fading when exposed to light. |   |                                |
|--|---|--------------------------------|
| LIGHTFASTNESS LEVEL (BLUE WOOL SCALE)  | DIRECT EXPOSURE SUMMER / WINTER                 | NORMAL CONDITIONS OF DISPLAY * |
| 1  | -   | less than 2 years              |
| 2  | -   | 2 - 15 years                   |
| 3  | 4 - 8 days / 2 - 4 weeks                        | 2 - 15 years                   |
| 4  | 2 - 3 weeks / 2 - 3 months                      | 15 - 50 years                  |
| 5  | 3 - 5 weeks / 4 - 5 months                      | 15 - 50 years                  |
| 6  | 6 - 8 weeks / 5 - 6 months                      | 50 - 100 years                 |
| 7  | 3 - 4 months / 7 - 9 months                     | over 100 years                 |
| 8  | over 1.5 years                                  | over 100 years                 |
| 8+   | exceeds performance of blue wool scale number 8 |                                |

## molo MATERIAL LIGHTFASTNESS

| COLOUR · MATERIAL         | LIGHTFASTNESS LEVEL (BLUE WOOL SCALE)   |
|---------------------------|---|
| brown paper               | 5 - 6 (fades to a slightly lighter shade of brown with prolonged sun exposure)  |
| black paper               | 5 (very slight reduction of the intensity of black with prolonged sun exposure) |
| blue paper                | 3 - 4   |
| deep blue paper           | 7   |
| heavyweight white textile | 8   |
| aluminum textile          | 8+  |
| forest green textile      | 8+  |
| brown PaperStone®         | 5   |
| black PaperStone®         | 7   |
| graphite wool felt        | 8   |

## TABLE TOPS

|                 |  |
|-----------------|--|
| PaperStone® top | The PaperStone® table top material is highly water resistant, suitable for wet environments and finished by molo with a clear, flat/matte, Milesi 7° sheen, polyurethane top coat. |
| marble top      | molo offers custom marble tops in Cararra White or Tlupana grey. Alternatively, drawings are available if you wish to fabricate a top locally.                                     |
| wool felt pad   | Made from 100% natural grey wool felt, the 89 cm pad can be used as a soft table surface.  |

## OPTIONAL ACCESSORIES

|                            |  |
|----------------------------|--|
| glass vase / pencil holder | glass vase is a delicate cylinder of borosilicate glass, handblown in the Czech Republic. The vase inserts into the hollow openings of the softwall + softblock honeycomb structure. |
| sketching circle           | The circular sheets of sketching circle revolve around a center pencil holder, allowing ideas to grow and develop as they pass around the table.                                     |
| LED kits                   | Integrated LED lighting is available for white textile cantilever table base. Please inquire for more information.   |

## 2D + 3D DRAWING FILES

AutoCAD, Sketchup, Revit, 3DS, and Rhino drawing files for cantilever table are available for download at <https://molodesign.com/documentation/product-drawings/>

## DOWNLOAD CERTIFICATES

Download all certificates at <https://molodesign.com/documentation/certifications/>

This drawing and the content represented is the exclusive property of molo design ltd. and cannot be used without their prior written consent. For site installations verify all dimensions and notify molo of any on-site discrepancies prior to construction. Drawing scale may be affected by printing, scanning, or copying. Do not scale drawings.



molo design, ltd.  
1470 Venables Street  
Vancouver, BC  
Canada V5L 2G7

+ 1 604 685 0340  
molodesign.com

Designed by Stephanie Forsythe and Todd MacAllen,  
manufactured by molo and protected by one or more patents and/or design registrations held by molo, viewable at [molodesign.com/ip](https://molodesign.com/ip)

cantilever table · SPECIFICATIONS AND CERTIFICATIONS  
all dimensions in mm unless otherwise noted

DATE: 260323

01

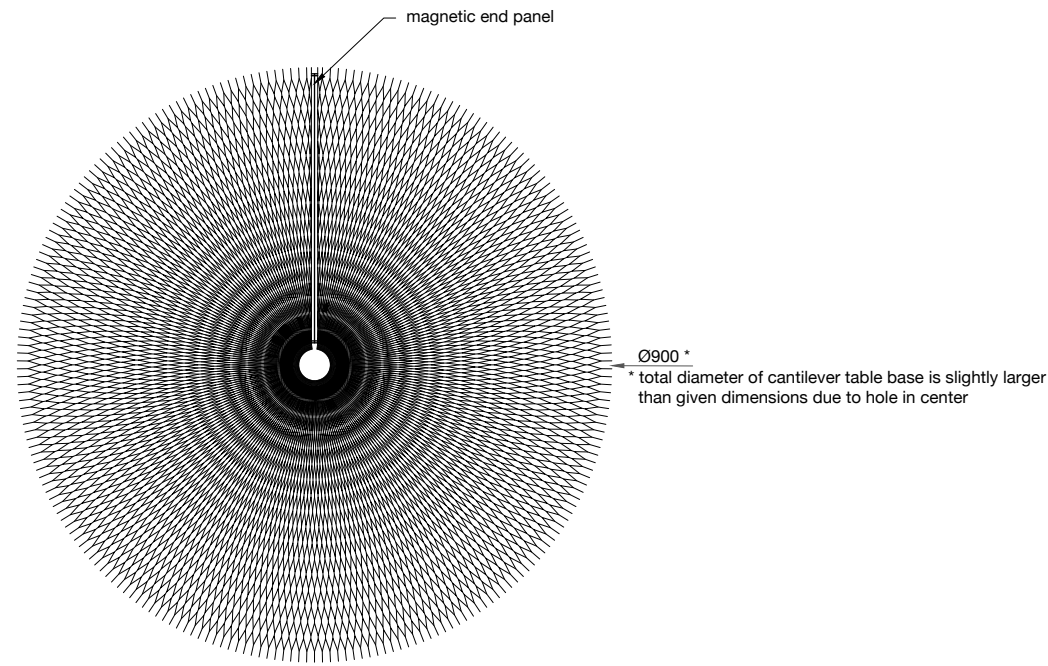

PLAN

| cantilever table base · sitting height · 685 mm tall x 900 mm diameter |                |                 |                          |
|--|----------------|-----------------|--------------------------|
| COLOUR · MATERIAL  | PRODUCT WEIGHT | SHIPPING WEIGHT | SKU                      |
| brown · paper  | 12.8 kg        | 17.4 kg         | M-CT-B-P-FSC-BR-27-37    |
| black · paper  | 13.2 kg        | 17.8 kg         | M-CT-B-P-BK-27-37        |
| blue · paper   | 13.2 kg        | 17.8 kg         | M-CT-B-P-FSC-BU-27-37    |
| deep blue · paper  | 13.2 kg        | 17.8 kg         | M-CT-B-P-FSC-DB281-27-37 |
| white · textile  | 9.0 kg         | 13.2 kg         | M-CT-B-T-WH-27-37        |
| aluminum · textile   | 9.6 kg         | 13.8 kg         | M-CT-B-T-AL-27-37        |
| forest green · textile   | 9.6 kg         | 13.8 kg         | M-CT-B-T-GRN-27-37       |

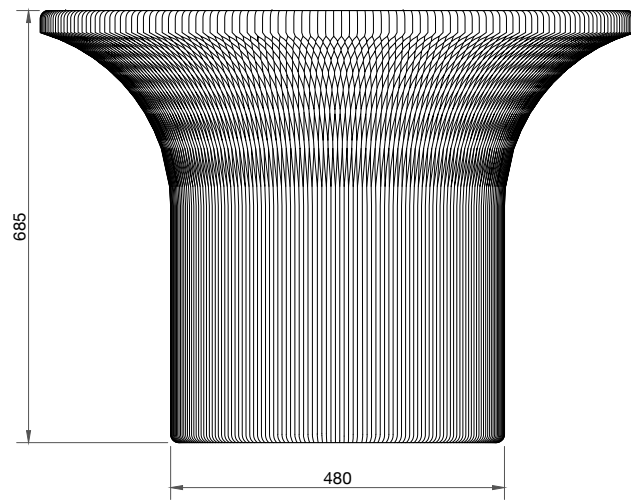

ELEVATION

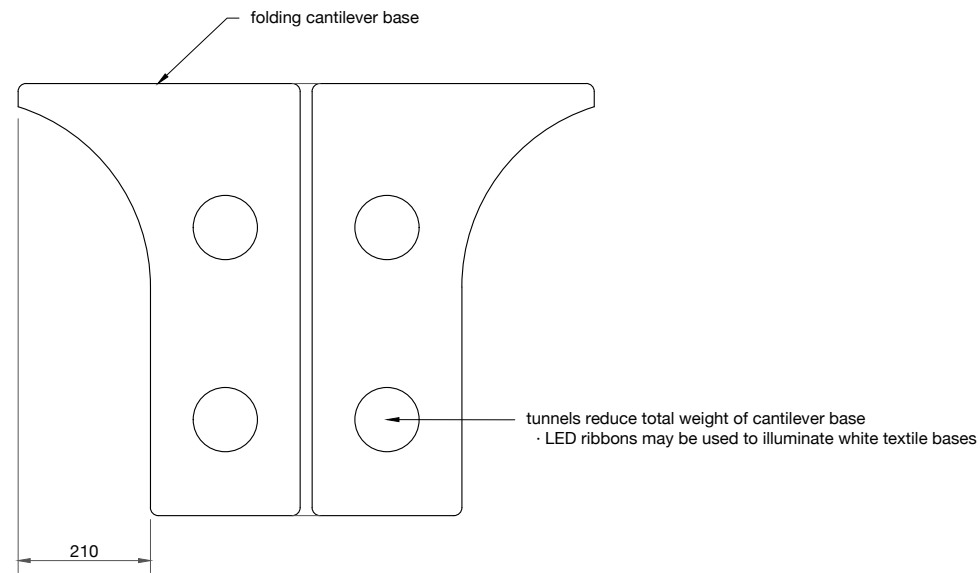

ELEVATION · SECTION VIEW

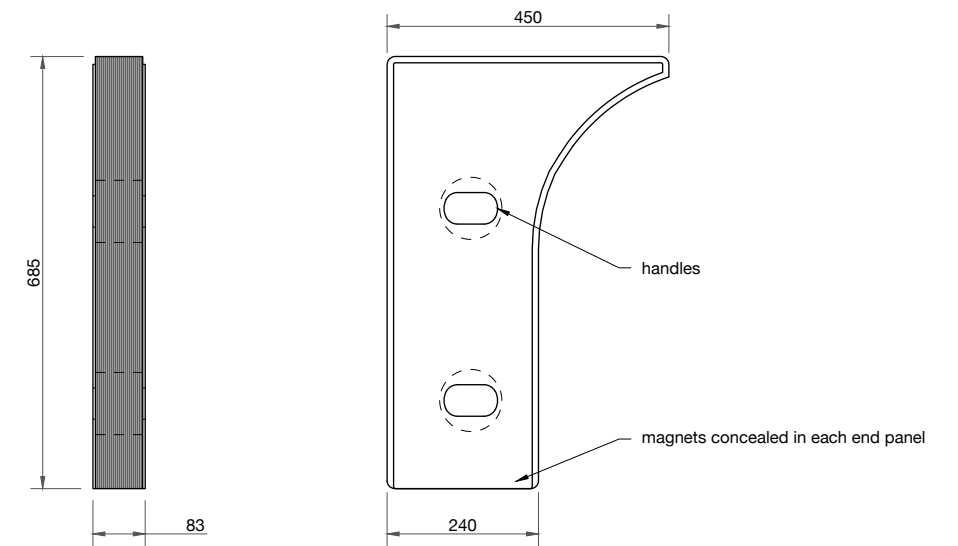

ELEVATION · COMPRESSED VIEWS

This drawing and the content represented is the exclusive property of molo design ltd. and cannot be used without their prior written consent. For site installations verify all dimensions and notify molo of any on-site discrepancies prior to construction. Drawing scale may be affected by printing, scanning, or copying. Do not scale drawings.



molo design, ltd.  
1470 Venables Street  
Vancouver, BC  
Canada V5L 2G7

+ 1 604 685 0340  
molodesign.com

Designed by Stephanie Forsythe and Todd MacAllen,  
manufactured by molo and protected by one or more patents and/or design registrations held by molo, viewable at molodesign.com/ip

cantilever table base · sitting height · SPECIFICATIONS  
all dimensions in mm unless otherwise noted  
SCALE · 1:12

DATE: 260323

| cantilever table base · standing height · 1003 mm tall x 900 mm diameter |                |                 |                          |
|--|----------------|-----------------|--------------------------|
| COLOUR · MATERIAL  | PRODUCT WEIGHT | SHIPPING WEIGHT | SKU                      |
| brown · paper  | 15.8 kg        | 21.5 kg         | M-CT-B-P-FSC-BR-39-37    |
| black · paper  | 16.1 kg        | 21.5 kg         | M-CT-B-P-BK-39-37        |
| deep blue · paper  | 16.1 kg        | 21.5 kg         | M-CT-B-P-FSC-DB281-39-37 |
| white · textile  | 12.8 kg        | 18.2 kg         | M-CT-B-T-WH-39-37        |
| aluminum · textile   | 13.8 kg        | 19.2 kg         | M-CT-B-T-AL-39-37        |
| forest green · textile   | 13.8 kg        | 19.2 kg         | M-CT-B-T-GRN-39-37       |

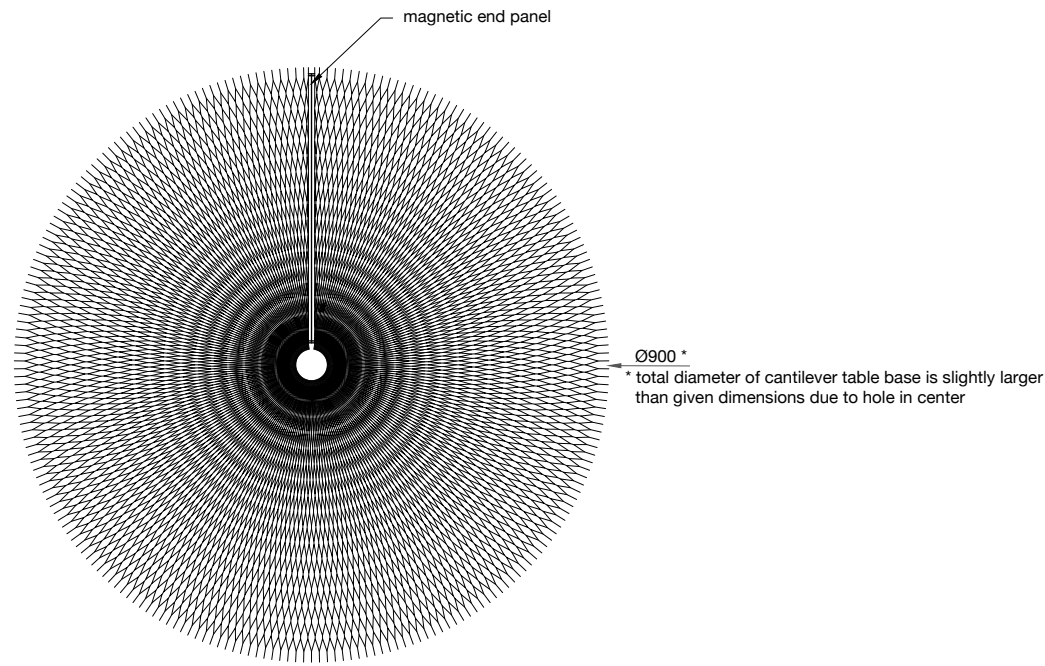

PLAN

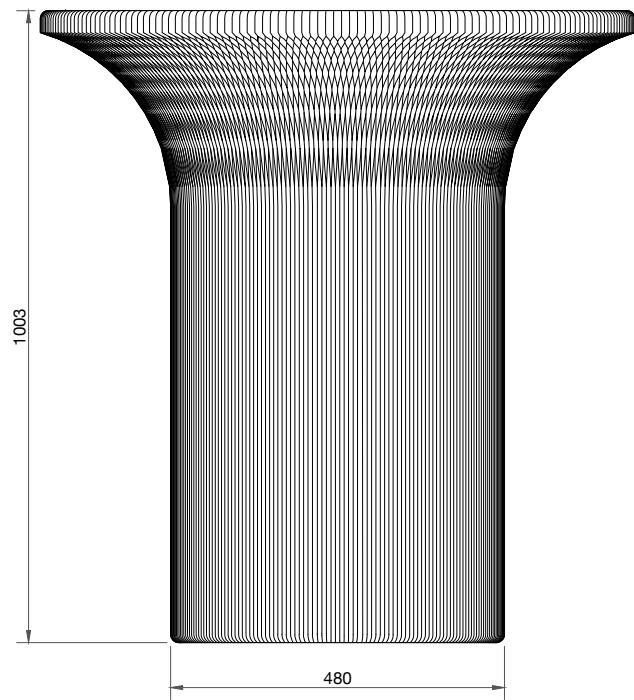

ELEVATION

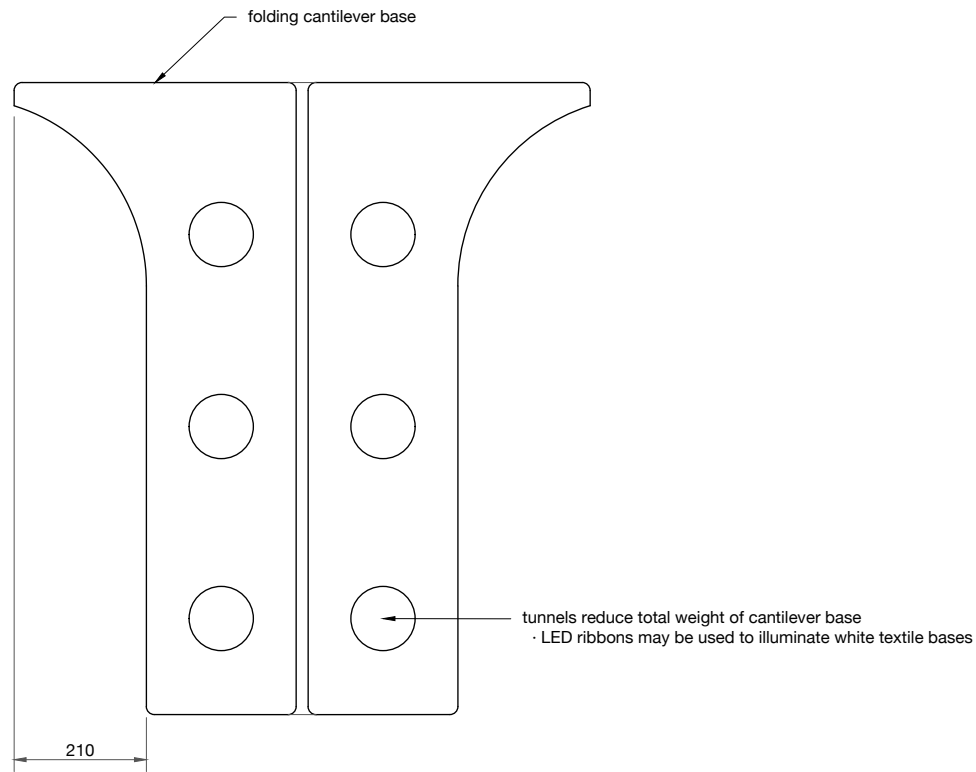

ELEVATION · SECTION VIEW

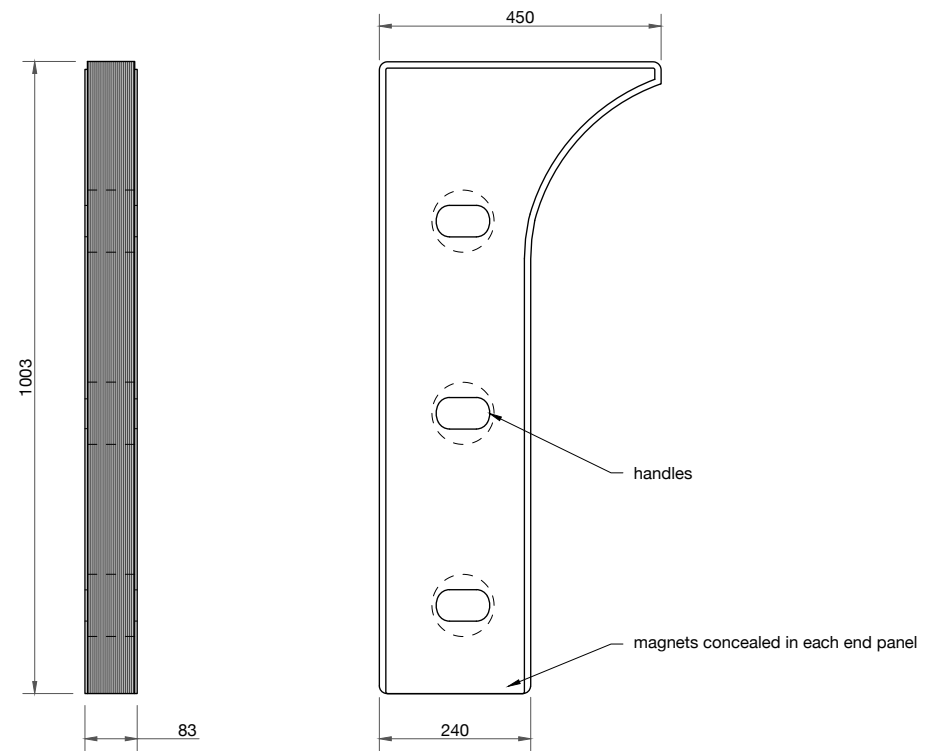

ELEVATION · COMPRESSED VIEWS

This drawing and the content represented is the exclusive property of molo design ltd. and cannot be used without their prior written consent. For site installations verify all dimensions and notify molo of any on-site discrepancies prior to construction. Drawing scale may be affected by printing, scanning, or copying. Do not scale drawings.



molo design, ltd.  
1470 Venables Street  
Vancouver, BC  
Canada V5L 2G7

+ 1 604 685 0340  
molodesign.com

Designed by Stephanie Forsythe and Todd MacAllen,  
manufactured by molo and protected by one or more patents and/or design registrations held by molo, viewable at molodesign.com/ip

cantilever table base · standing height · SPECIFICATIONS  
all dimensions in mm unless otherwise noted  
SCALE · 1:12

DATE: 260323

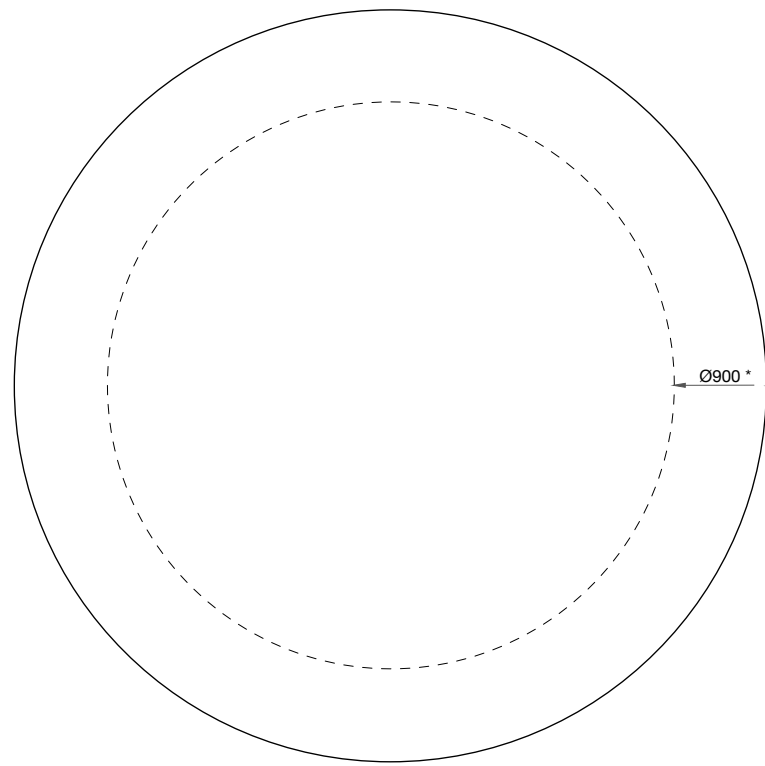

\* total diameter of cantilever table base is slightly larger than given dimensions due to hole in center

PLAN

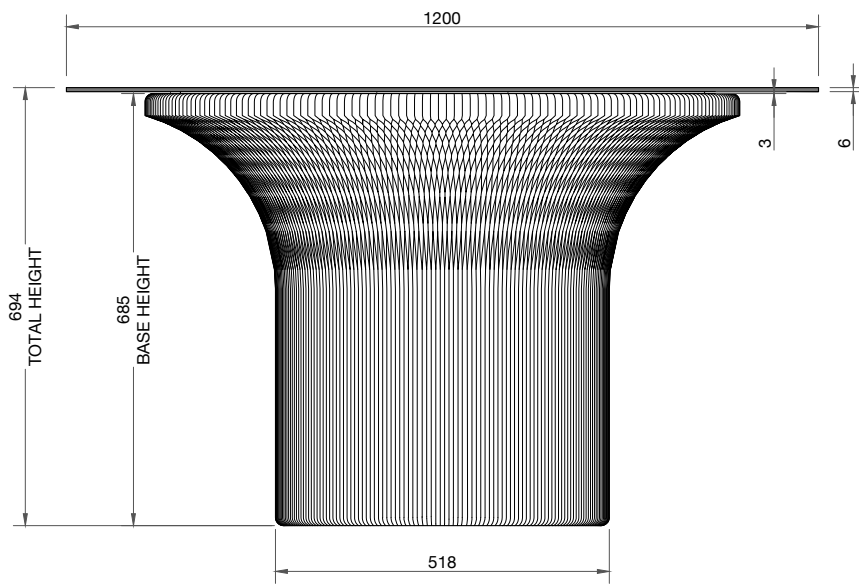

ELEVATION

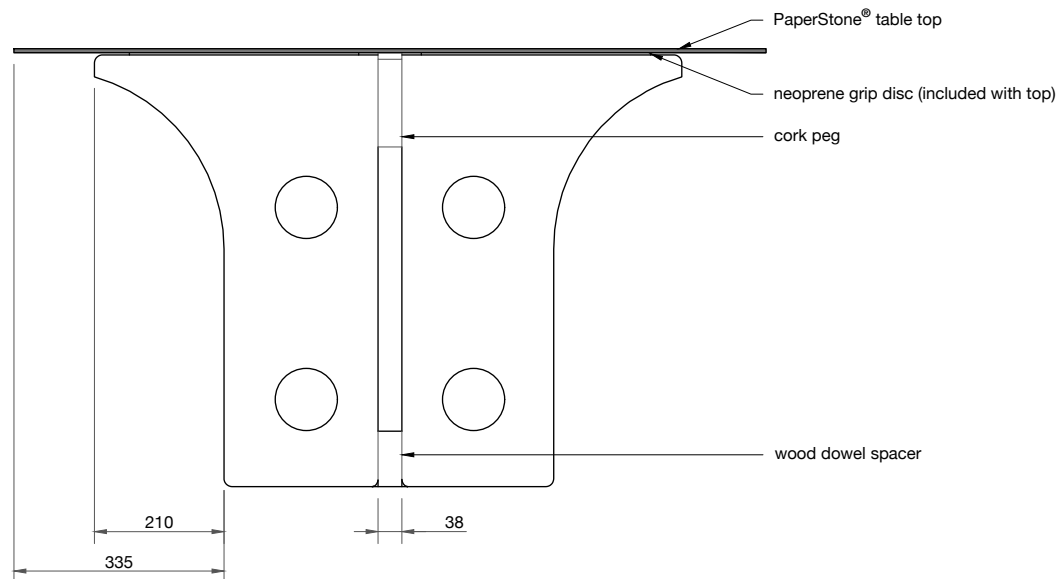

ELEVATION - SECTION VIEW

| cantilever table base · sitting height · 685 mm tall x 900 mm diameter |                |                 |                          |
|--|----------------|-----------------|--------------------------|
| COLOUR · MATERIAL  | PRODUCT WEIGHT | SHIPPING WEIGHT | SKU                      |
| brown · paper  | 12.8 kg        | 17.4 kg         | M-CT-B-P-FSC-BR-27-37    |
| black · paper  | 13.2 kg        | 17.8 kg         | M-CT-B-P-BK-27-37        |
| blue · paper   | 13.2 kg        | 17.8 kg         | M-CT-B-P-FSC-BU-27-37    |
| deep blue · paper  | 13.2 kg        | 17.8 kg         | M-CT-B-P-FSC-DB281-27-37 |
| white · textile  | 9.0 kg         | 13.2 kg         | M-CT-B-T-WH-27-37        |
| aluminum · textile   | 9.6 kg         | 13.8 kg         | M-CT-B-T-AL-27-37        |
| forest green · textile   | 9.6 kg         | 13.8 kg         | M-CT-B-T-GRN-27-37       |

| PaperStone® table top with countersink · 1200 mm diameter |                |                 |                    |
|---|----------------|-----------------|--------------------|
| COLOUR · MATERIAL   | PRODUCT WEIGHT | SHIPPING WEIGHT | SKU                |
| brown · PaperStone (FSC® C013501)                         | 8.4 kg         | 13.0 kg         | M-CT-T-P-FSC-BR-47 |
| black · PaperStone (FSC® C013501)                         | 9.7 kg         | 14.3 kg         | M-CT-T-P-FSC-BK-47 |

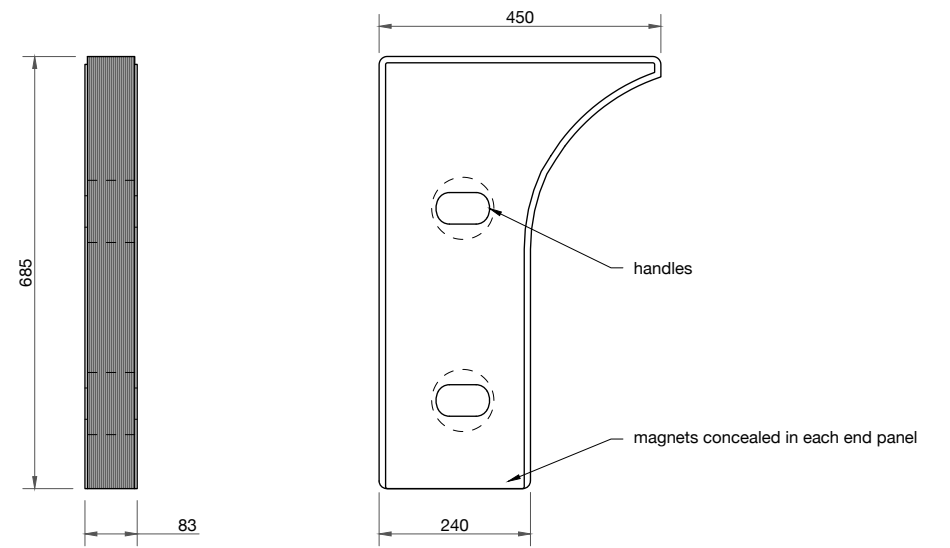

ELEVATION - COMPRESSED VIEWS

This drawing and the content represented is the exclusive property of molo design ltd. and cannot be used without their prior written consent. For site installations verify all dimensions and notify molo of any on-site discrepancies prior to construction. Drawing scale may be affected by printing, scanning, or copying. Do not scale drawings.



molo design, ltd.  
1470 Venables Street  
Vancouver, BC  
Canada V5L 2G7

+ 1 604 685 0340  
molodesign.com

Designed by Stephanie Forsythe and Todd MacAllen,  
manufactured by molo and protected by one or more patents and/or design registrations held by molo, viewable at molodesign.com/ip

cantilever table · sitting height · PaperStone® TABLE TOP WITH COUNTERSINK · SPECIFICATIONS  
all dimensions in mm unless otherwise noted  
SCALE · 1:12

DATE: 260323

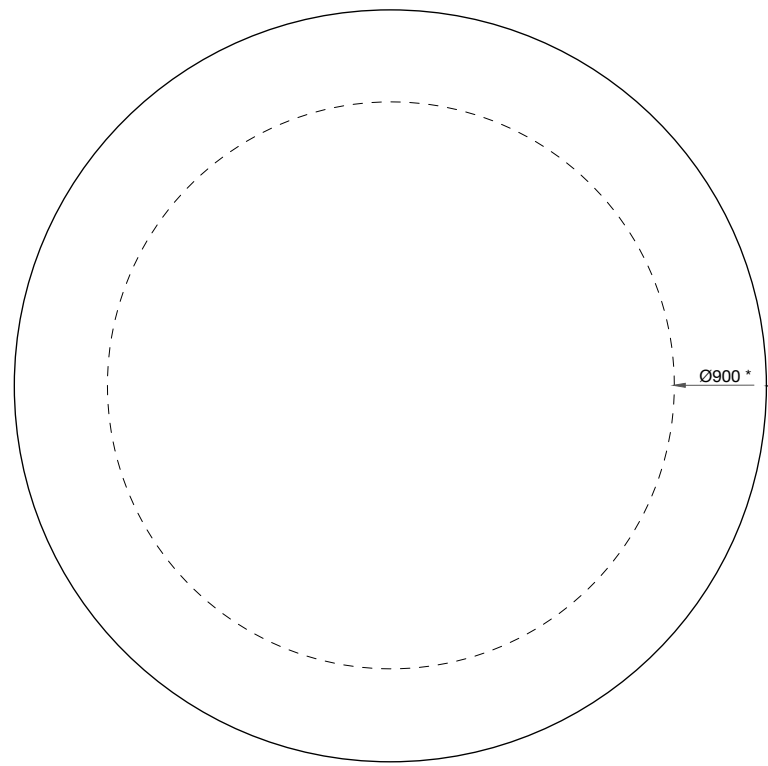

\* total diameter of cantilever table base is slightly larger than given dimensions due to hole in center

| cantilever table base · standing height · 1003 mm tall x 900 mm diameter |                |                 |                          |
|--|----------------|-----------------|--------------------------|
| COLOUR · MATERIAL  | PRODUCT WEIGHT | SHIPPING WEIGHT | SKU                      |
| brown · paper  | 15.8 kg        | 21.5 kg         | M-CT-B-P-FSC-BR-39-37    |
| black · paper  | 16.1 kg        | 21.5 kg         | M-CT-B-P-BK-39-37        |
| deep blue · paper  | 16.1 kg        | 21.5 kg         | M-CT-B-P-FSC-DB281-39-37 |
| white · textile  | 12.8 kg        | 18.2 kg         | M-CT-B-T-WH-39-37        |
| aluminum · textile   | 13.8 kg        | 19.2 kg         | M-CT-B-T-AL-39-37        |
| forest green · textile   | 13.8 kg        | 19.2 kg         | M-CT-B-T-GRN-39-37       |

| PaperStone® table top with countersink · 1200 mm diameter |                |                 |                    |
|---|----------------|-----------------|--------------------|
| COLOUR · MATERIAL   | PRODUCT WEIGHT | SHIPPING WEIGHT | SKU                |
| brown · PaperStone (FSC® C013501)                         | 8.4 kg         | 13.0 kg         | M-CT-T-P-FSC-BR-47 |
| black · PaperStone (FSC® C013501)                         | 9.7 kg         | 14.3 kg         | M-CT-T-P-FSC-BK-47 |

PLAN

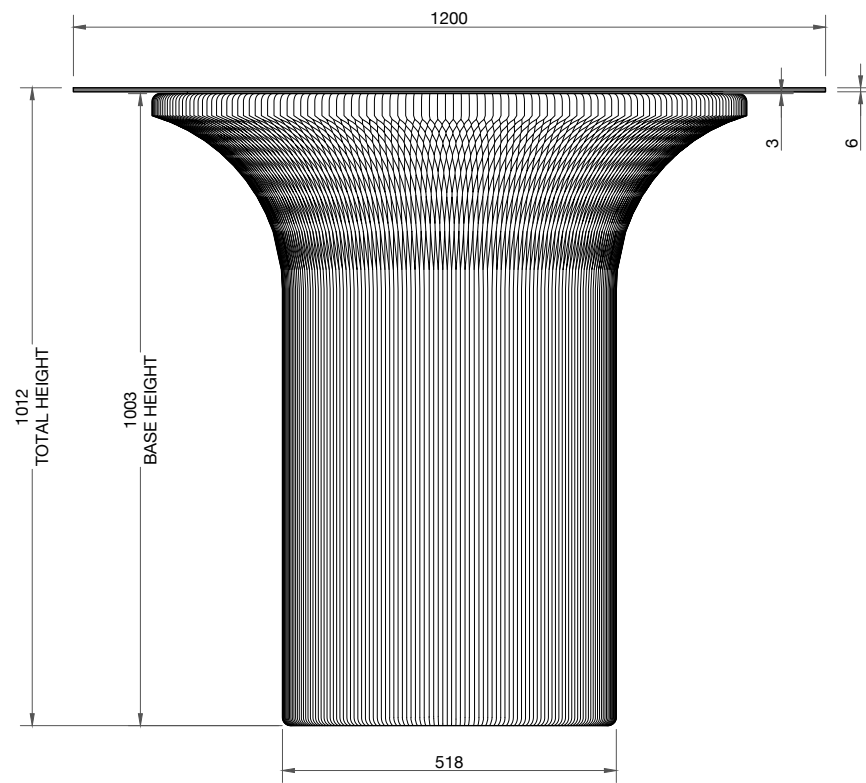

ELEVATION

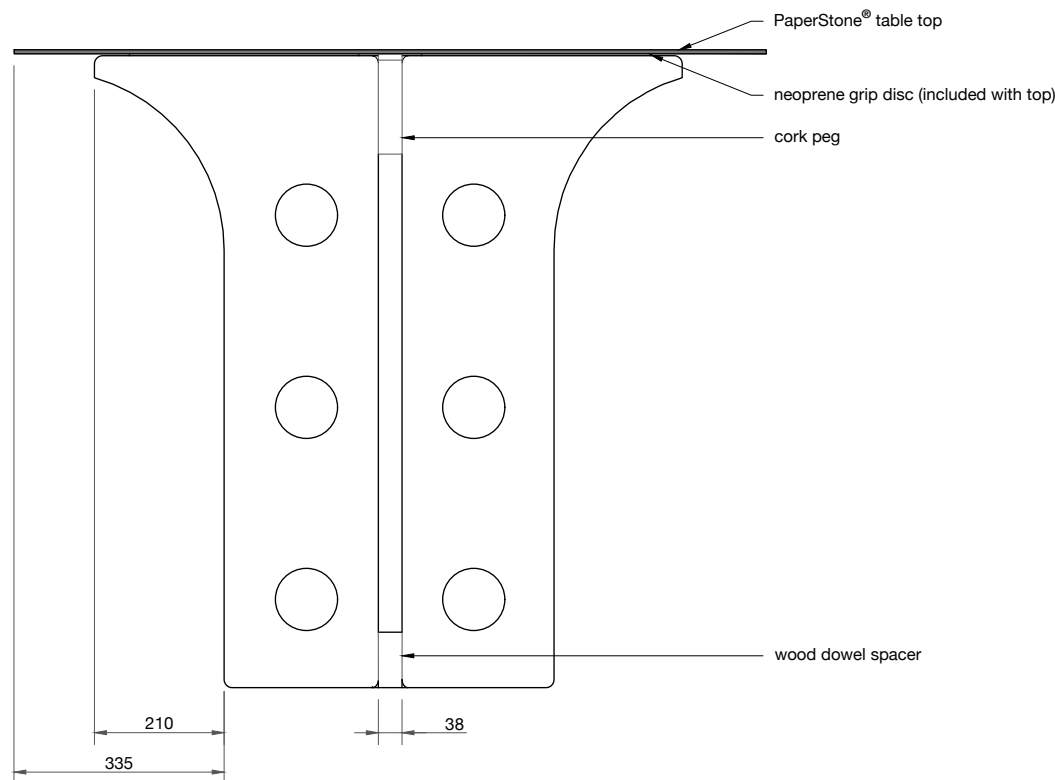

ELEVATION · SECTION VIEW

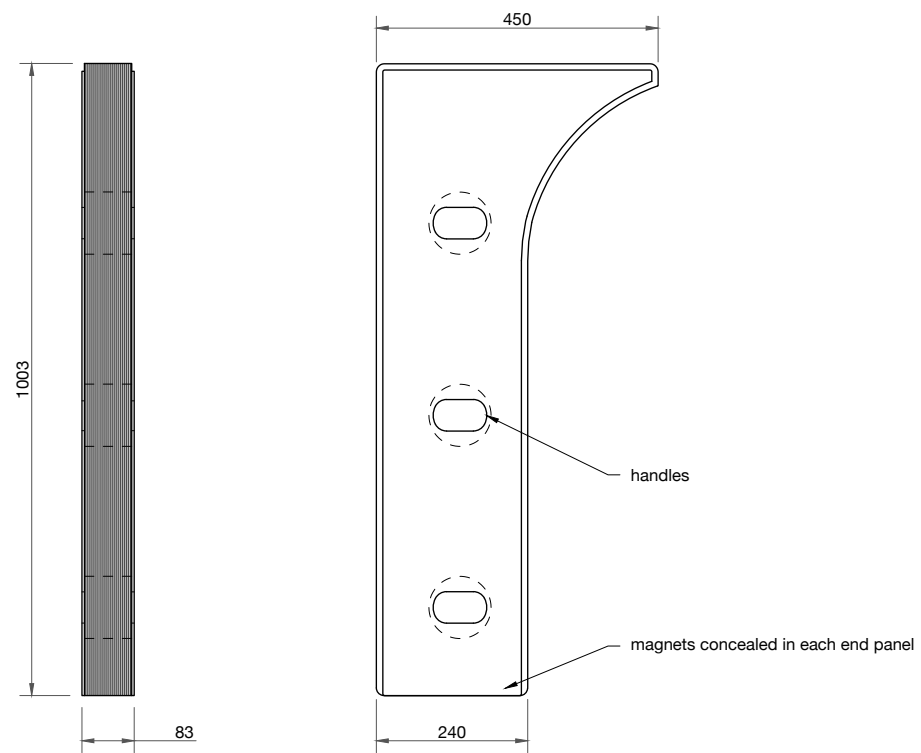

ELEVATION · COMPRESSED VIEWS

This drawing and the content represented is the exclusive property of molo design ltd. and cannot be used without their prior written consent. For site installations verify all dimensions and notify molo of any on-site discrepancies prior to construction. Drawing scale may be affected by printing, scanning, or copying. Do not scale drawings.



molo design, ltd.  
1470 Venables Street  
Vancouver, BC  
Canada V5L 2G7

+ 1 604 685 0340  
molodesign.com

Designed by Stephanie Forsythe and Todd MacAllen,  
manufactured by molo and protected by one or more patents and/or design registrations held by molo, viewable at molodesign.com/ip

cantilever table · standing height · PaperStone® TABLE TOP WITH COUNTERSINK · SPECIFICATIONS  
all dimensions in mm unless otherwise noted  
SCALE · 1:12

DATE: 260323

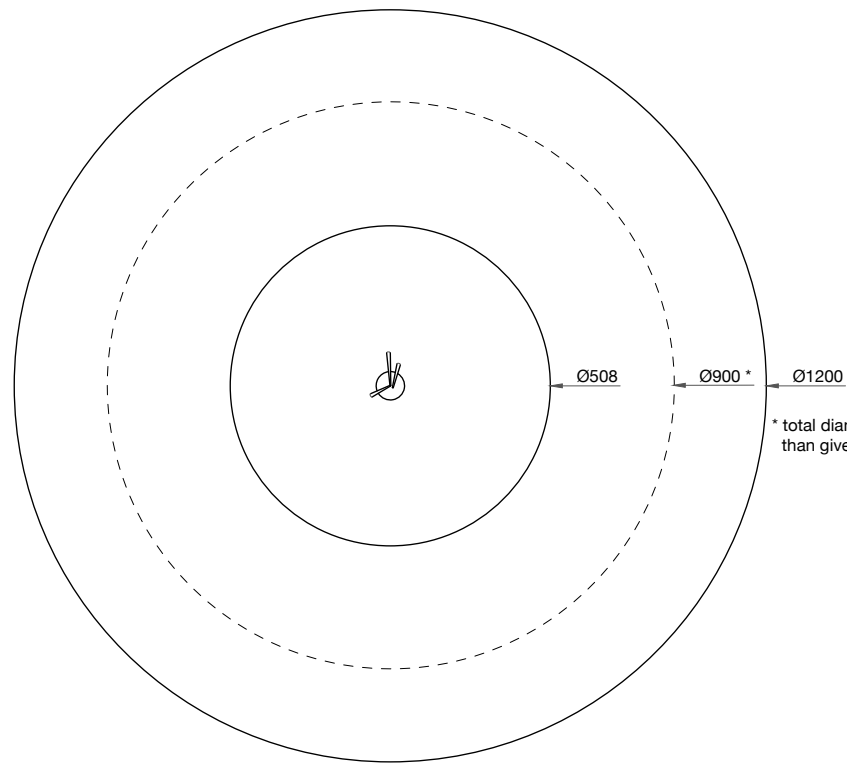

\* total diameter of cantilever table base is slightly larger than given dimensions due to hole in center

PLAN

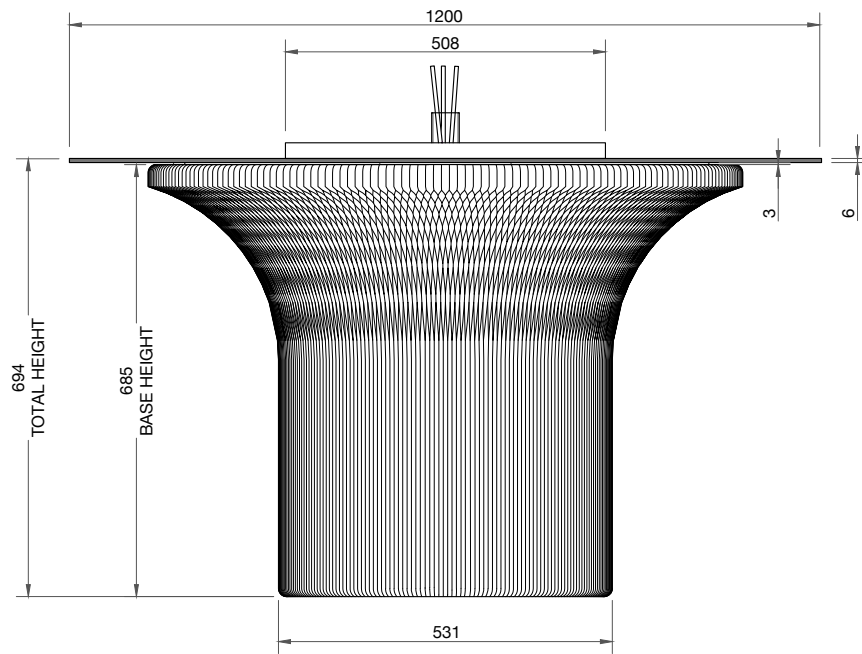

ELEVATION

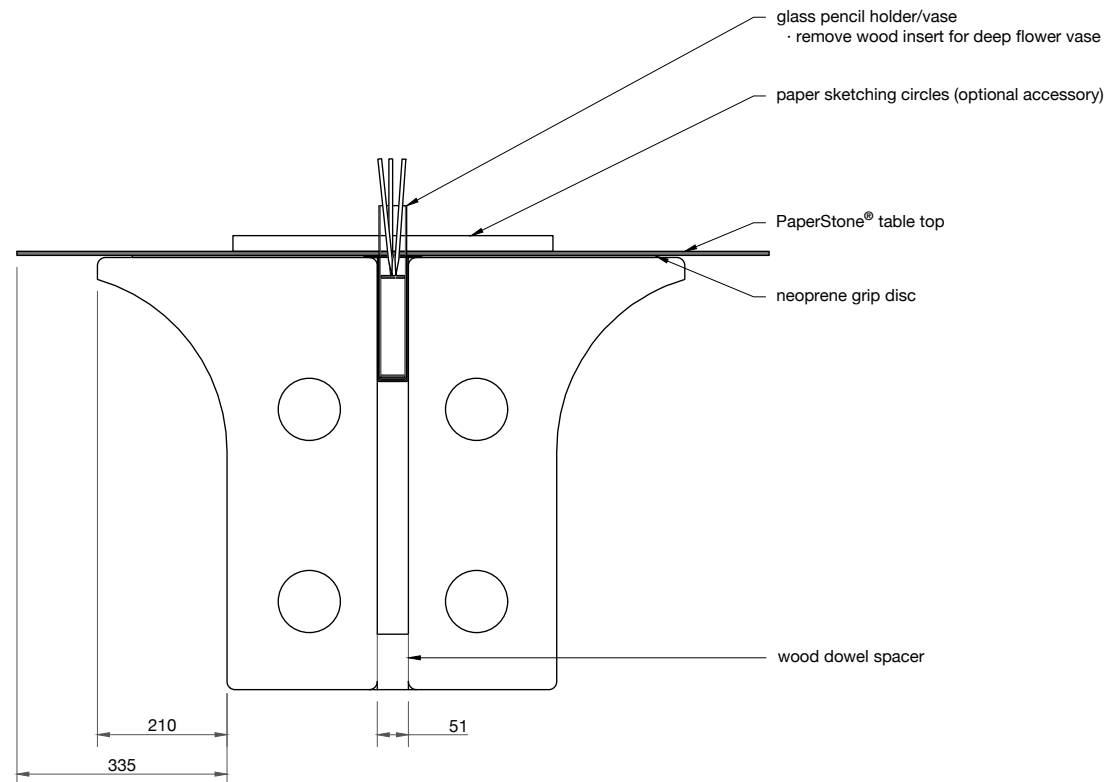

ELEVATION · SECTION VIEW

| cantilever table base · sitting height · 685 mm tall x 900 mm diameter |                |                 |                          |
|--|----------------|-----------------|--------------------------|
| COLOUR · MATERIAL  | PRODUCT WEIGHT | SHIPPING WEIGHT | SKU                      |
| brown · paper  | 12.8 kg        | 17.4 kg         | M-CT-B-P-FSC-BR-27-37    |
| black · paper  | 13.2 kg        | 17.8 kg         | M-CT-B-P-BK-27-37        |
| blue · paper   | 13.2 kg        | 17.8 kg         | M-CT-B-P-FSC-BU-27-37    |
| deep blue · paper  | 13.2 kg        | 17.8 kg         | M-CT-B-P-FSC-DB281-27-37 |
| white · textile  | 9.0 kg         | 13.2 kg         | M-CT-B-T-WH-27-37        |
| aluminum · textile   | 9.6 kg         | 13.8 kg         | M-CT-B-T-AL-27-37        |
| forest green · textile   | 9.6 kg         | 13.8 kg         | M-CT-B-T-GRN-27-37       |

| PaperStone® table top with center hole · 1200 mm diameter |                |                 |                      |
|---|----------------|-----------------|----------------------|
| COLOUR · MATERIAL   | PRODUCT WEIGHT | SHIPPING WEIGHT | SKU                  |
| brown · PaperStone (FSC® C013501)                         | 8.4 kg         | 13.0 kg         | M-CT-T-H-P-FSC-BR-47 |
| black · PaperStone (FSC® C013501)                         | 9.7 kg         | 14.3 kg         | M-CT-T-H-P-FSC-BK-47 |

| paper sketching circles · 508 mm diameter |            |                 |                 |
|---|------------|-----------------|-----------------|
| MATERIAL                                  | SIZE       | SHIPPING WEIGHT | SKU             |
| paper                                     | 400 sheets | 8.9 kg          | M-CT-SC-P-WH-20 |

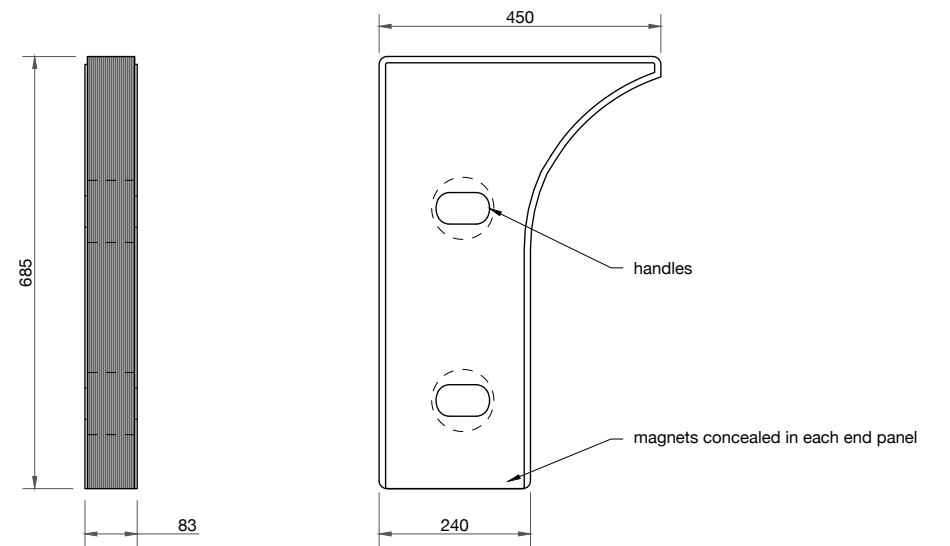

ELEVATION · COMPRESSED VIEWS

This drawing and the content represented is the exclusive property of molo design ltd. and cannot be used without their prior written consent. For site installations verify all dimensions and notify molo of any on-site discrepancies prior to construction. Drawing scale may be affected by printing, scanning, or copying. Do not scale drawings.



molo design, ltd.  
1470 Venables Street  
Vancouver, BC  
Canada V5L 2G7

+ 1 604 685 0340  
molodesign.com

Designed by Stephanie Forsythe and Todd MacAllen,  
manufactured by molo and protected by one or more patents and/or design registrations held by molo, viewable at molodesign.com/ip

cantilever table · sitting height · PaperStone® TABLE TOP WITH CENTER HOLE · SPECIFICATIONS  
all dimensions in mm unless otherwise noted  
SCALE · 1:12

DATE: 260323

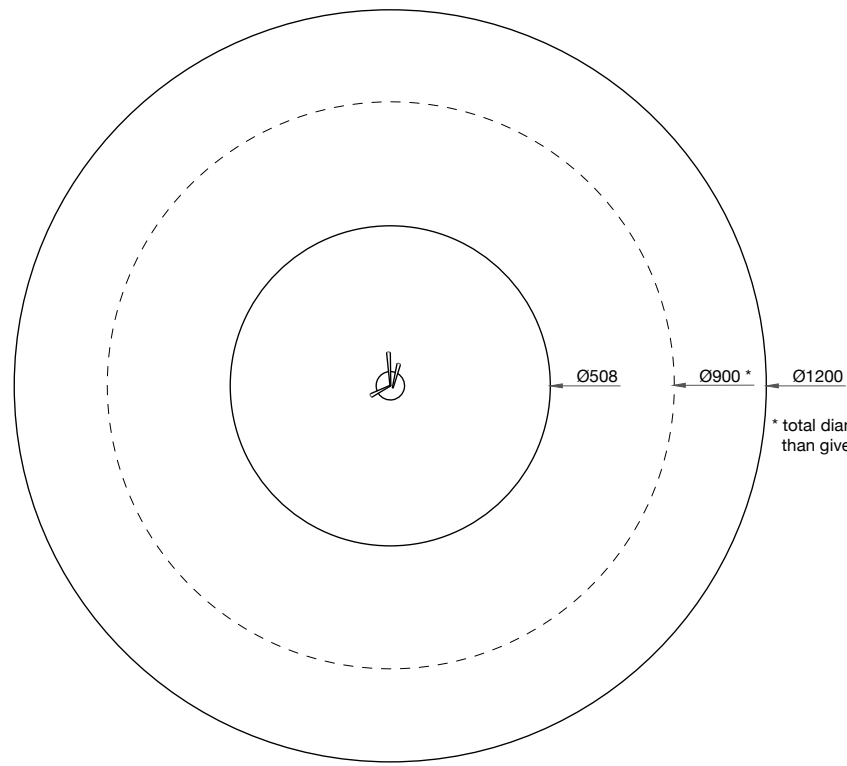

| cantilever table base · standing height · 1003 mm tall x 900 mm diameter |                |                 |                          |
|--|----------------|-----------------|--------------------------|
| COLOUR · MATERIAL  | PRODUCT WEIGHT | SHIPPING WEIGHT | SKU                      |
| brown · paper  | 15.8 kg        | 21.5 kg         | M-CT-B-P-FSC-BR-39-37    |
| black · paper  | 16.1 kg        | 21.5 kg         | M-CT-B-P-BK-39-37        |
| deep blue · paper  | 16.1 kg        | 21.5 kg         | M-CT-B-P-FSC-DB281-39-37 |
| white · textile  | 12.8 kg        | 18.2 kg         | M-CT-B-T-WH-39-37        |
| aluminum · textile   | 13.8 kg        | 19.2 kg         | M-CT-B-T-AL-39-37        |
| forest green · textile   | 13.8 kg        | 19.2 kg         | M-CT-B-T-GRN-39-37       |

| PaperStone® table top with center hole · 1200 mm diameter |                |                 |                      |
|---|----------------|-----------------|----------------------|
| COLOUR · MATERIAL   | PRODUCT WEIGHT | SHIPPING WEIGHT | SKU                  |
| brown · PaperStone (FSC® C013501)                         | 10.6 kg        | 14.0 kg         | M-CT-T-H-P-FSC-BR-47 |
| black · PaperStone (FSC® C013501)                         | 10.6 kg        | 14.3 kg         | M-CT-T-H-P-FSC-BK-47 |

| paper sketching circles · 508 mm diameter |            |                 |                 |
|---|------------|-----------------|-----------------|
| MATERIAL                                  | SIZE       | SHIPPING WEIGHT | SKU             |
| paper                                     | 400 sheets | 8.9 kg          | M-CT-SC-P-WH-20 |

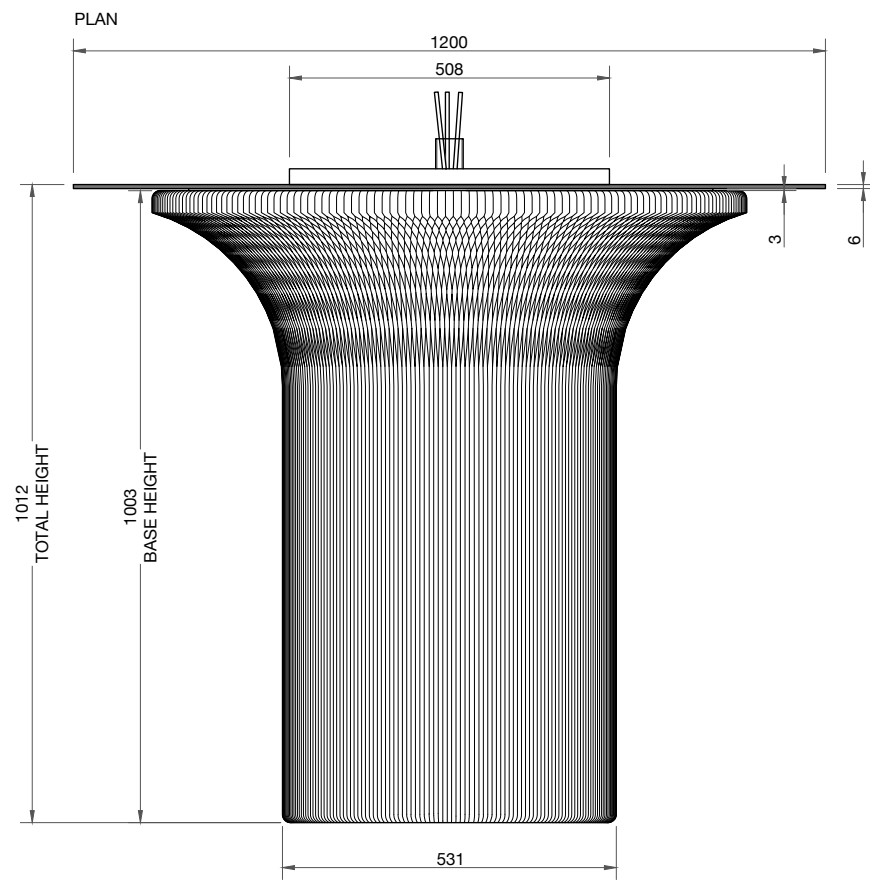

ELEVATION

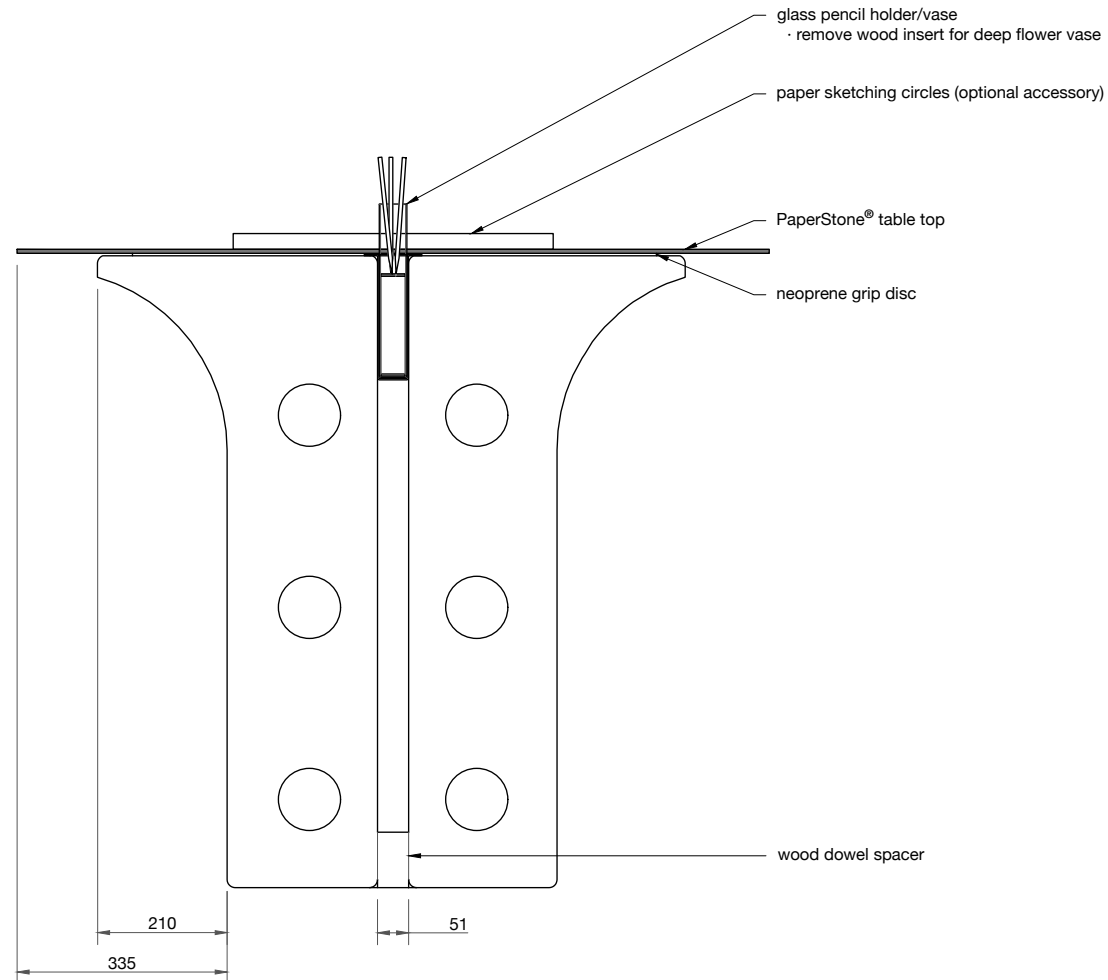

ELEVATION · SECTION VIEW

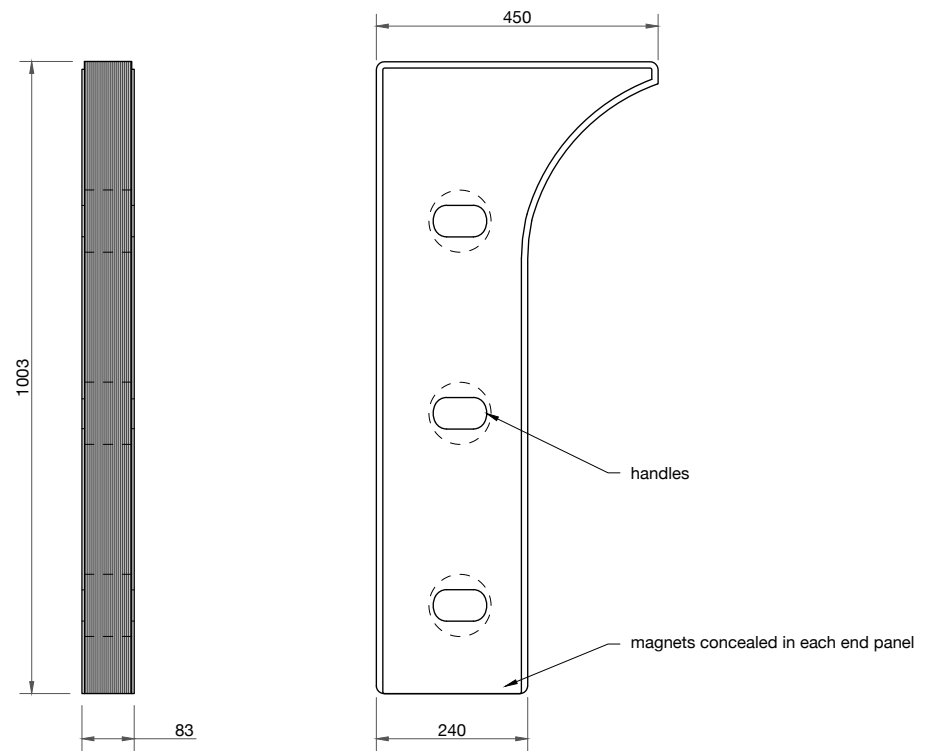

ELEVATION · COMPRESSED VIEWS

This drawing and the content represented is the exclusive property of molo design ltd. and cannot be used without their prior written consent. For site installations verify all dimensions and notify molo of any on-site discrepancies prior to construction. Drawing scale may be affected by printing, scanning, or copying. Do not scale drawings.

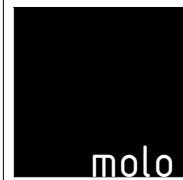

molo design, ltd.  
1470 Venables Street  
Vancouver, BC  
Canada V5L 2G7

+ 1 604 685 0340  
molodesign.com

Designed by Stephanie Forsythe and Todd MacAllen,  
manufactured by molo and protected by one or more patents and/or design registrations held by molo, viewable at molodesign.com/ip

cantilever table · standing height · PaperStone® TABLE TOP WITH CENTER HOLE · SPECIFICATIONS  
all dimensions in mm unless otherwise noted  
SCALE · 1:12

DATE: 260323

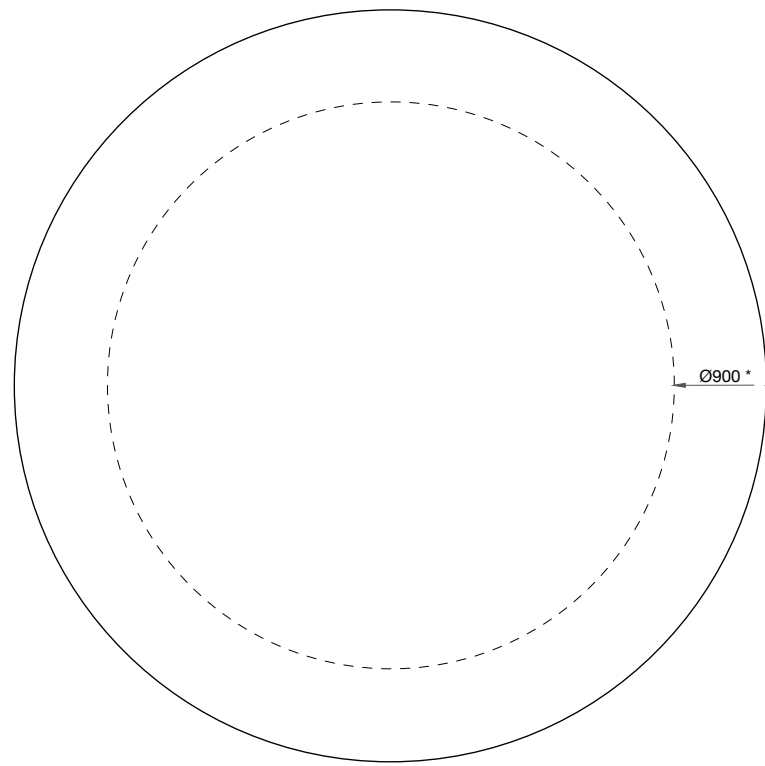

\* total diameter of cantilever table base is slightly larger than given dimensions due to hole in center

PLAN

| cantilever table base · sitting height · 685 mm tall x 900 mm diameter |                |                 |                          |
|--|----------------|-----------------|--------------------------|
| COLOUR · MATERIAL  | PRODUCT WEIGHT | SHIPPING WEIGHT | SKU                      |
| brown · paper  | 12.8 kg        | 17.4 kg         | M-CT-B-P-FSC-BR-27-37    |
| black · paper  | 13.2 kg        | 17.8 kg         | M-CT-B-P-BK-27-37        |
| blue · paper   | 13.2 kg        | 17.8 kg         | M-CT-B-P-FSC-BU-27-37    |
| deep blue · paper  | 13.2 kg        | 17.8 kg         | M-CT-B-P-FSC-DB281-27-37 |
| white · textile  | 9.0 kg         | 13.2 kg         | M-CT-B-T-WH-27-37        |
| aluminum · textile   | 9.6 kg         | 13.8 kg         | M-CT-B-T-AL-27-37        |
| forest green · textile   | 9.6 kg         | 13.8 kg         | M-CT-B-T-GRN-27-37       |

| marble table top with countersink · 1200 mm diameter |                |                 |                  |
|--|----------------|-----------------|------------------|
| COLOUR · MATERIAL                                    | PRODUCT WEIGHT | SHIPPING WEIGHT | SKU              |
| Carrara white · marble                               | 61.8 kg        | please inquire  | M-CT-T-MAR-WH-47 |
| Tlupana grey · marble                                | 61.8 kg        | please inquire  | M-CT-T-MAR-GR-47 |

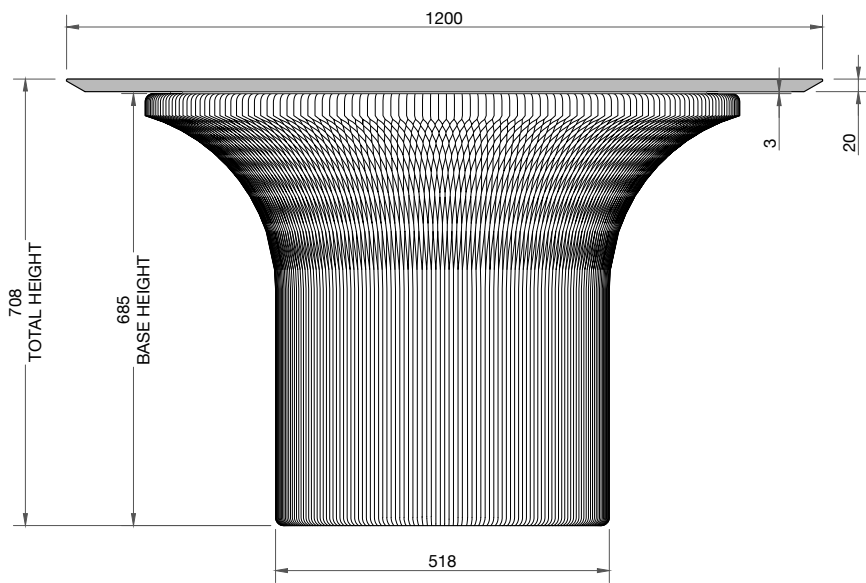

ELEVATION

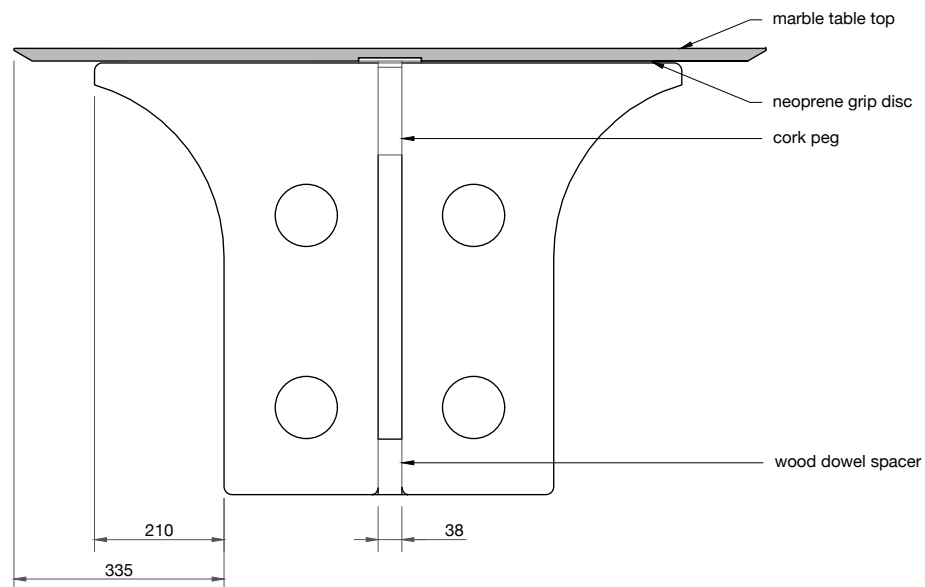

ELEVATION · SECTION VIEW

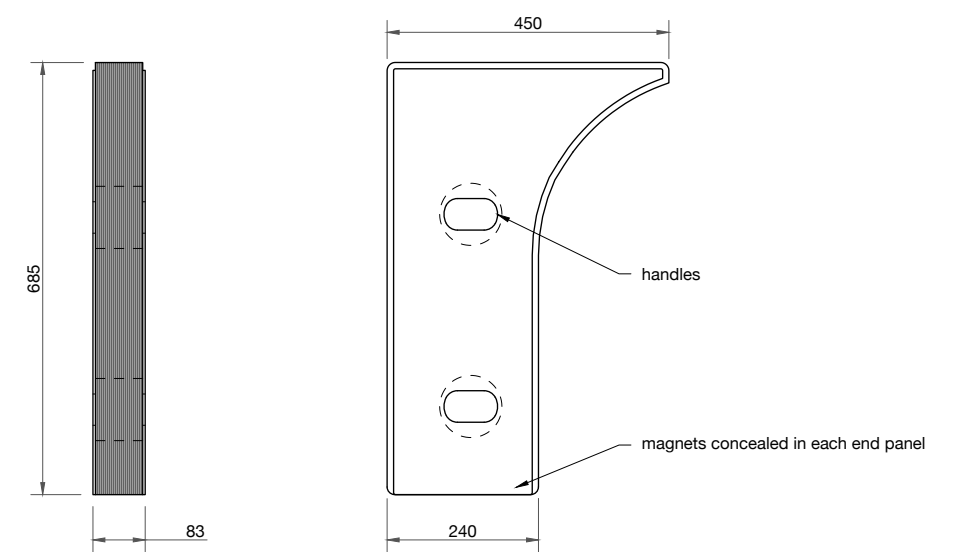

ELEVATION · COMPRESSED VIEWS

This drawing and the content represented is the exclusive property of molo design ltd. and cannot be used without their prior written consent. For site installations verify all dimensions and notify molo of any on-site discrepancies prior to construction. Drawing scale may be affected by printing, scanning, or copying. Do not scale drawings.



molo design, ltd.  
1470 Venables Street  
Vancouver, BC  
Canada V5L 2G7

+ 1 604 685 0340  
molodesign.com

Designed by Stephanie Forsythe and Todd MacAllen,  
manufactured by molo and protected by one or more patents and/or design registrations held by molo, viewable at molodesign.com/ip

cantilever table · sitting height · MARBLE TABLE TOP WITH COUNTERSINK · SPECIFICATIONS  
all dimensions in mm unless otherwise noted  
SCALE · 1:12

DATE: 260323

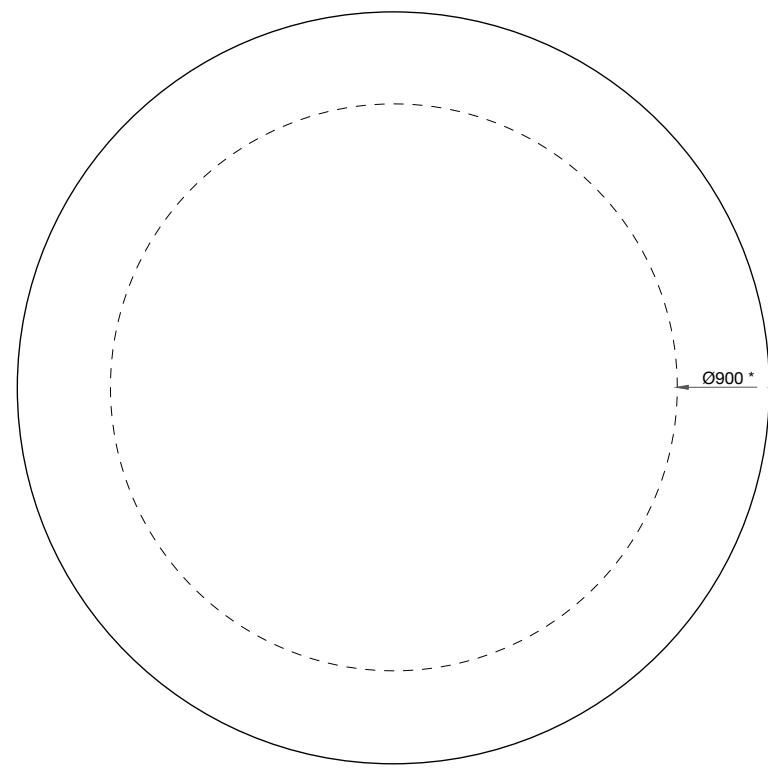

\* total diameter of cantilever table base is slightly larger than given dimensions due to hole in center

| cantilever table base · standing height · 1003 mm tall x 900 mm diameter |                |                 |                          |
|--|----------------|-----------------|--------------------------|
| COLOUR · MATERIAL  | PRODUCT WEIGHT | SHIPPING WEIGHT | SKU                      |
| brown · paper  | 15.8 kg        | 21.5 kg         | M-CT-B-P-FSC-BR-39-37    |
| black · paper  | 16.1 kg        | 21.5 kg         | M-CT-B-P-BK-39-37        |
| deep blue · paper  | 16.1 kg        | 21.5 kg         | M-CT-B-P-FSC-DB281-39-37 |
| white · textile  | 12.8 kg        | 18.2 kg         | M-CT-B-T-WH-39-37        |
| aluminum · textile   | 13.8 kg        | 19.2 kg         | M-CT-B-T-AL-39-37        |
| forest green · textile   | 13.8 kg        | 19.2 kg         | M-CT-B-T-GRN-39-37       |

| marble table top with countersink · 1200 mm diameter |                |                 |                  |
|--|----------------|-----------------|------------------|
| COLOUR · MATERIAL                                    | PRODUCT WEIGHT | SHIPPING WEIGHT | SKU              |
| Carrara white · marble                               | 61.8 kg        | please inquire  | M-CT-T-MAR-WH-47 |
| Tlupana grey · marble                                | 61.8 kg        | please inquire  | M-CT-T-MAR-GR-47 |

PLAN

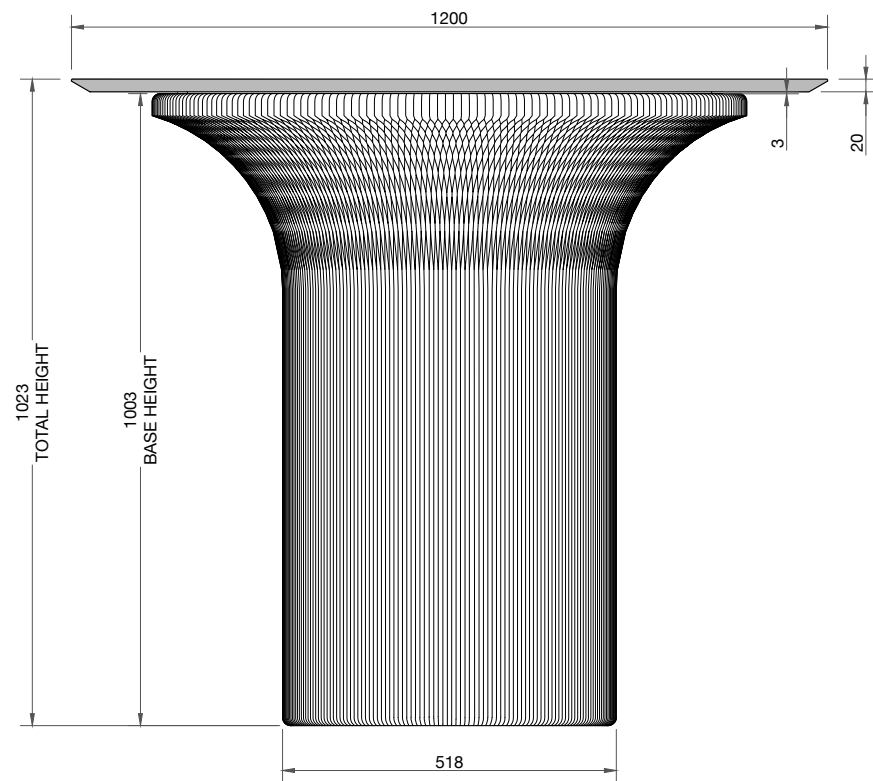

ELEVATION

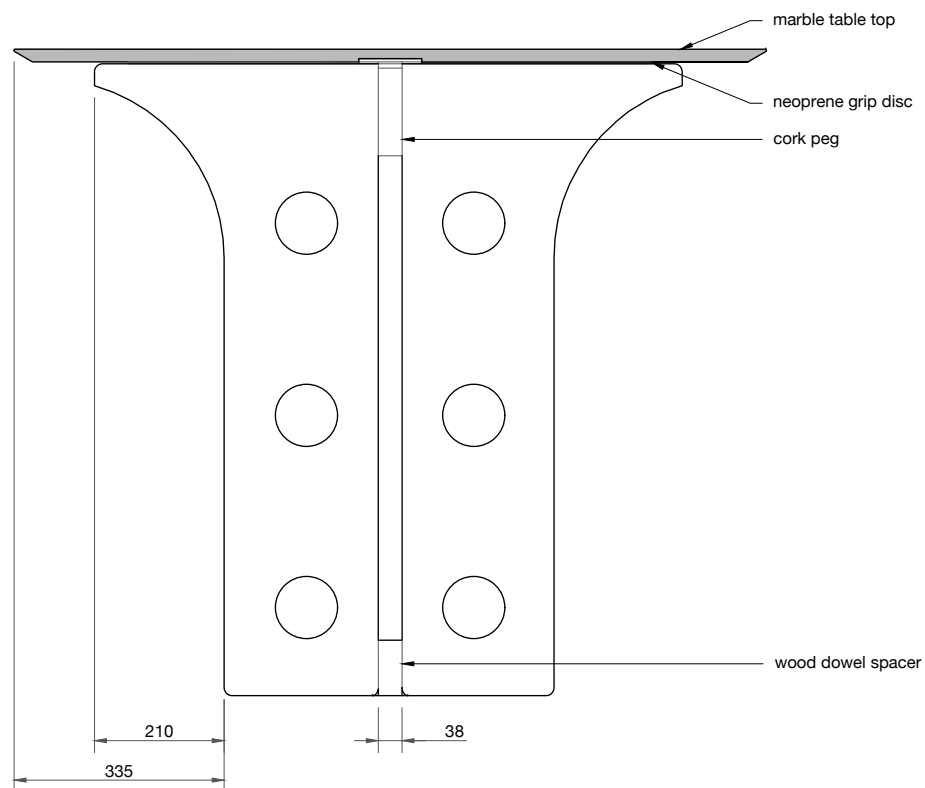

ELEVATION · SECTION VIEW

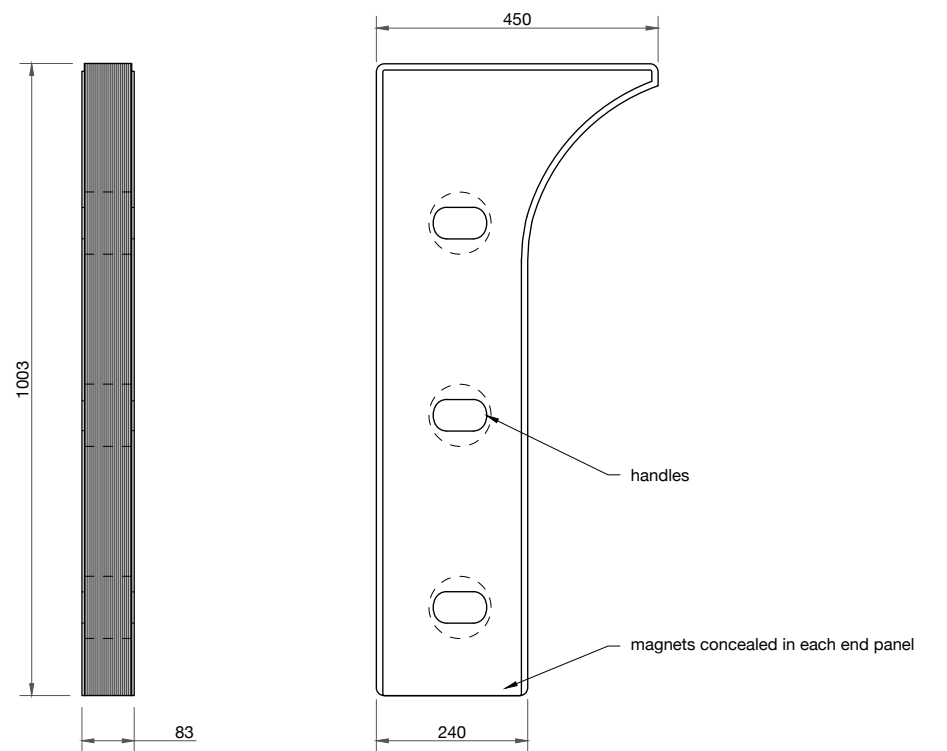

ELEVATION · COMPRESSED VIEWS

This drawing and the content represented is the exclusive property of molo design ltd. and cannot be used without their prior written consent. For site installations verify all dimensions and notify molo of any on-site discrepancies prior to construction. Drawing scale may be affected by printing, scanning, or copying. Do not scale drawings.



molo design, ltd.  
1470 Venables Street  
Vancouver, BC  
Canada V5L 2G7

+ 1 604 685 0340  
molodesign.com

Designed by Stephanie Forsythe and Todd MacAllen,  
manufactured by molo and protected by one or more patents and/or design registrations held by molo, viewable at molodesign.com/ip

cantilever table · standing height · MARBLE TABLE TOP WITH COUNTERSINK · SPECIFICATIONS  
all dimensions in mm unless otherwise noted  
SCALE · 1:12

DATE: 260323

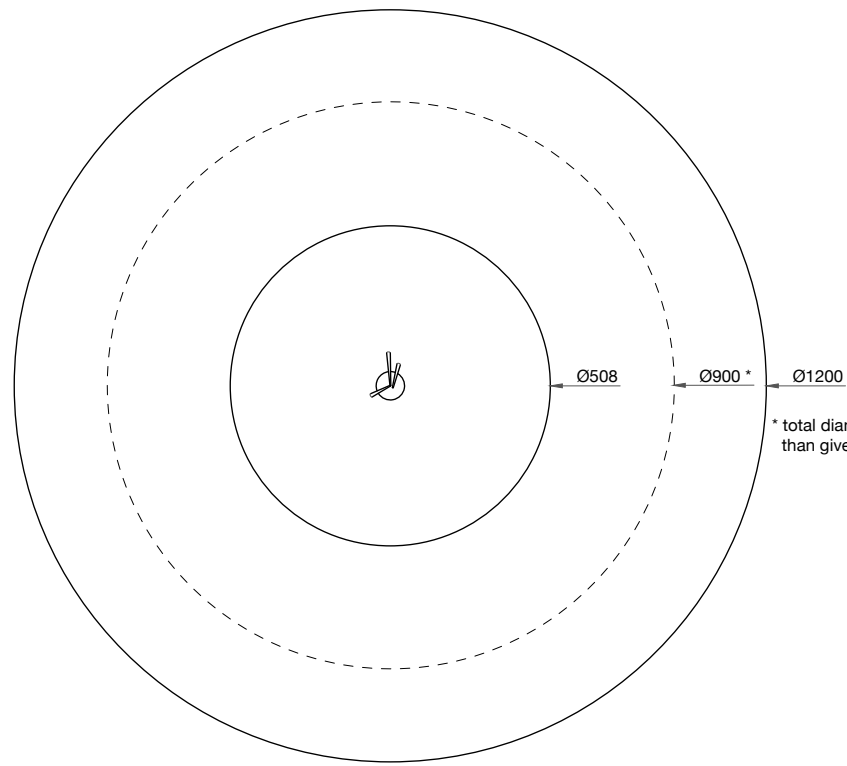

\* total diameter of cantilever table base is slightly larger than given dimensions due to hole in center

PLAN

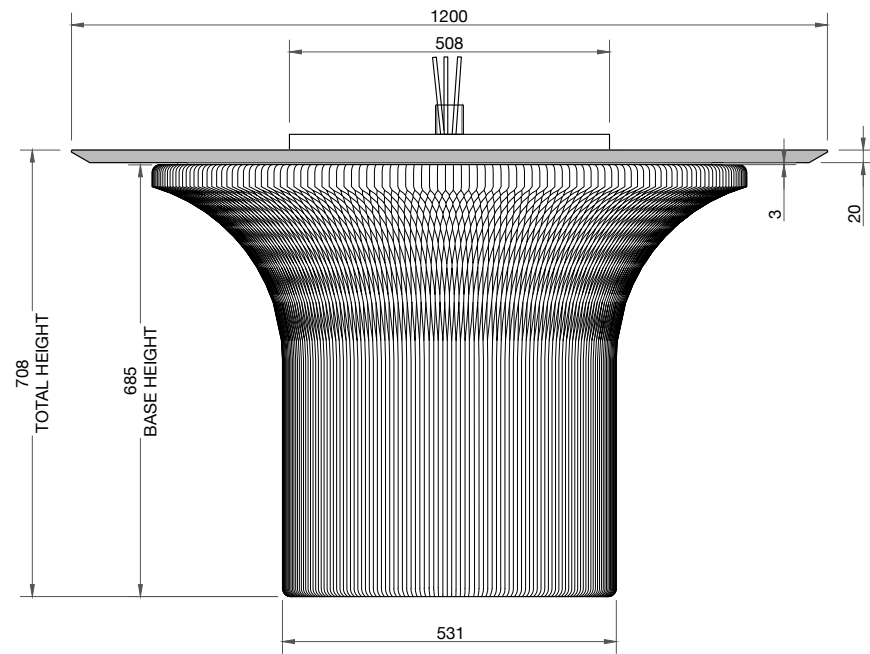

ELEVATION

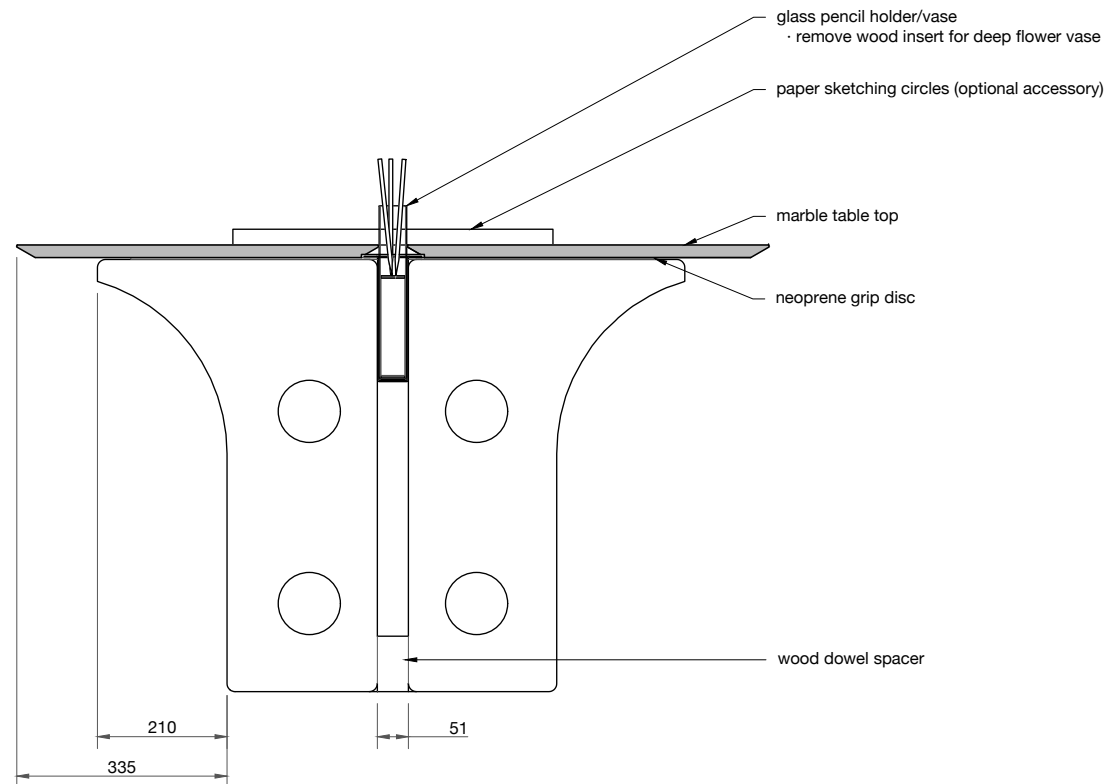

ELEVATION - SECTION VIEW

| cantilever table base - sitting height - 685 mm tall x 900 mm diameter |                |                 |                          |
|--|----------------|-----------------|--------------------------|
| COLOUR · MATERIAL  | PRODUCT WEIGHT | SHIPPING WEIGHT | SKU                      |
| brown · paper  | 12.8 kg        | 17.4 kg         | M-CT-B-P-FSC-BR-27-37    |
| black · paper  | 13.2 kg        | 17.8 kg         | M-CT-B-P-BK-27-37        |
| blue · paper   | 13.2 kg        | 17.8 kg         | M-CT-B-P-FSC-BU-27-37    |
| deep blue · paper  | 13.2 kg        | 17.8 kg         | M-CT-B-P-FSC-DB281-27-37 |
| white · textile  | 9.0 kg         | 13.2 kg         | M-CT-B-T-WH-27-37        |
| aluminum · textile   | 9.6 kg         | 13.8 kg         | M-CT-B-T-AL-27-37        |
| forest green · textile   | 9.6 kg         | 13.8 kg         | M-CT-B-T-GRN-27-37       |

| marble table top with center hole - 1200 mm diameter |                |                 |                    |
|--|----------------|-----------------|--------------------|
| COLOUR · MATERIAL                                    | PRODUCT WEIGHT | SHIPPING WEIGHT | SKU                |
| Carrara white · marble                               | 61.8 kg        | please inquire  | M-CT-T-H-MAR-WH-47 |
| Tiupana grey · marble                                | 61.8 kg        | please inquire  | M-CT-T-H-MAR-GR-47 |

| paper sketching circles - 508 mm diameter |            |                 |                 |
|---|------------|-----------------|-----------------|
| MATERIAL                                  | SIZE       | SHIPPING WEIGHT | SKU             |
| paper                                     | 400 sheets | 8.9 kg          | M-CT-SC-P-WH-20 |

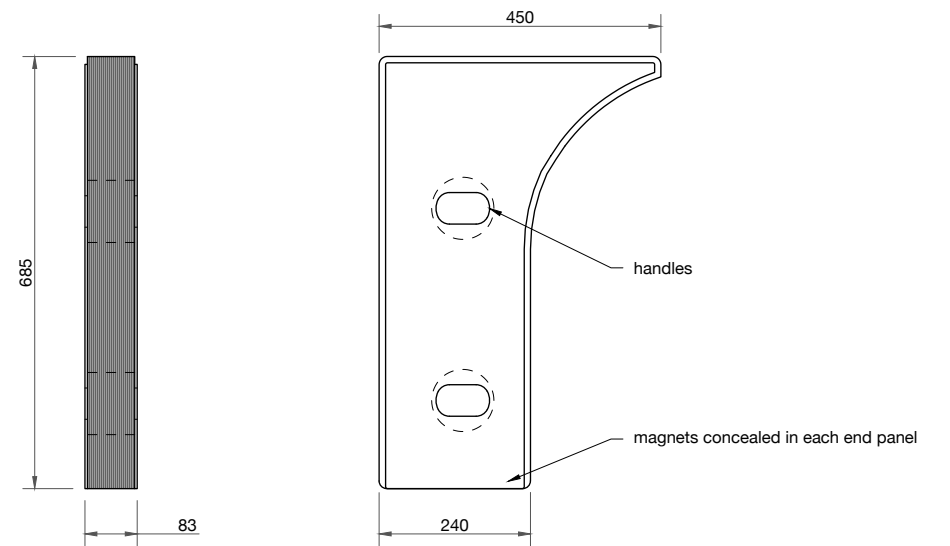

ELEVATION - COMPRESSED VIEWS

This drawing and the content represented is the exclusive property of molo design ltd. and cannot be used without their prior written consent. For site installations verify all dimensions and notify molo of any on-site discrepancies prior to construction. Drawing scale may be affected by printing, scanning, or copying. Do not scale drawings.



molo design, ltd.  
1470 Venables Street  
Vancouver, BC  
Canada V5L 2G7

+ 1 604 685 0340  
molodesign.com

Designed by Stephanie Forsythe and Todd MacAllen,  
manufactured by molo and protected by one or more patents and/or design registrations held by molo, viewable at molodesign.com/ip

cantilever table - sitting height · MARBLE TABLE TOP WITH CENTER HOLE · SPECIFICATIONS  
all dimensions in mm unless otherwise noted  
SCALE · 1:12

DATE: 260323

